

6

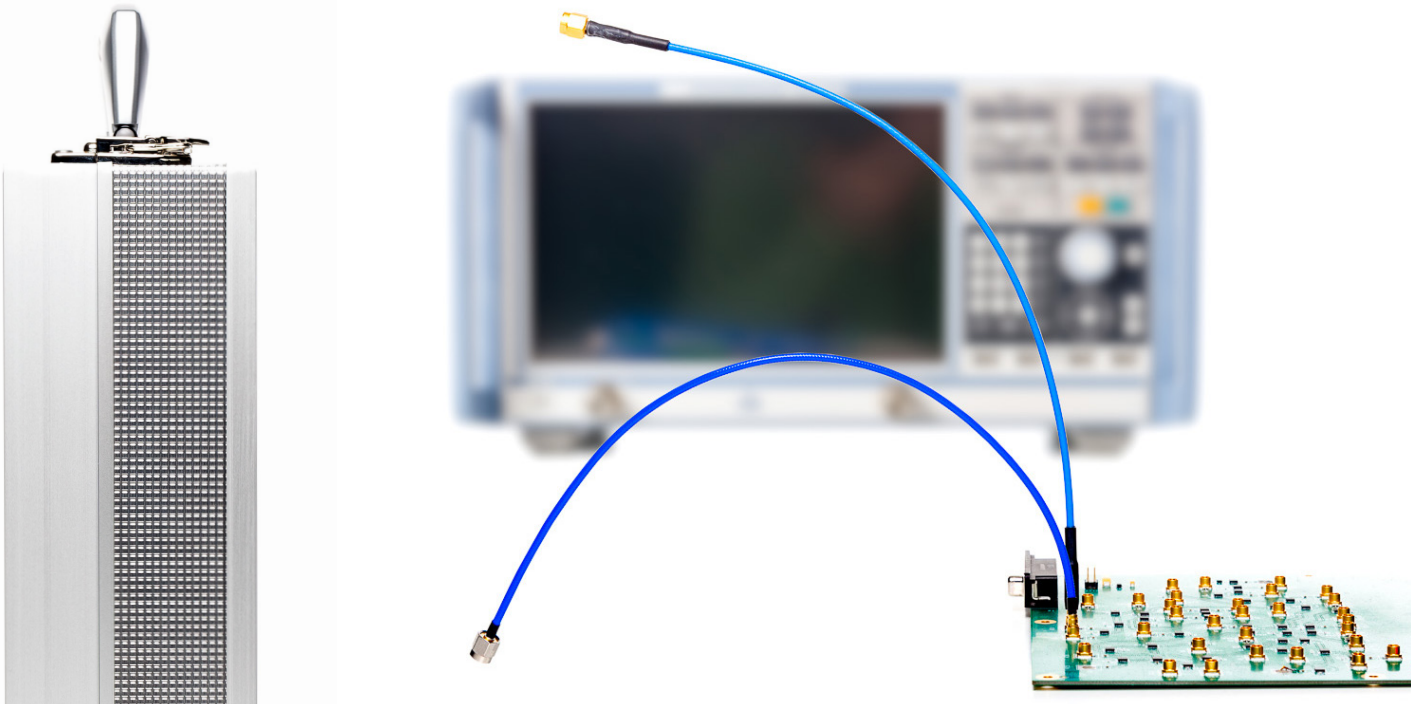

Simply Better Measurements

Why high-grade cables, matched adapters and the right torque enable higher-precision results

Dipl. Ing. Stefan Burger
Dipl. Ing. Thomas Weber

About the author

Stefan Burger received his engineering degree from the Offenburg University of Applied Science in 1986. He remained a research associate at the university until 1990. He then transferred to the research and development department of Endress + Hauser in Maulburg.

Until 2001, he was involved in the development of level measuring devices based on RADAR. Among other things, he was responsible for the support of the RADAR modules as well as the development of antennas and pressure-resistant RF components.

From 2001 to 2011, he worked on filters and duplexers for base stations as well as SAW filters at Panasonic Electronic Devices in Lüneburg. He was responsible for the "Lifetime and Power Durability" simulation.

In 2012, he founded his own company, Delta Gamma Consultant (www.delta-gamma.com), in Hampton, Australia. Since 2014, he has been working as an exclusive consultant in the area of RF and measurement technology for el-spec GmbH in Geretsried, Germany.

6

Simply Better Measurements.

Dipl. Ing. Thomas Weber
Dipl. Ing. (FH) Stefan Burger | Delta Gamma RF-Expert

Content

Preface	5
1. Coaxial connections.....	7
2. The measurement setup	11
3. Calibration	15
4. Optimize matching	16
5. VSWR (Voltage Standing Wave Ratio).....	17
6. The reflection factor	17
7. The unit „Bel“	18
8. The coaxial cable	19
9. Various types of connectors	21
10. The portable elspec Premium Measurement Kit 18GHz.....	24
Notes.....	32



Preface

The lab has the most sensitive test-devices ready for use. Staff have been trained extensively on the specifics, and conscientiously prepared for diverse new testing possibilities. Precision and extreme accuracy are a natural for each and everyone of the involved test engineers.

The expectations are considerable since a significant budget has already been invested. To ensure the quality chain continues, the very best cables, adapters and connectors should be used.

This is why elspec has developed the portable Premium Measurement Kit for you. It includes all the commonplace connection parts such as microwave cable assembly for 18 GHz, adapter N/SMA und SUCOFORM® 86 jumper cables with protective cap, plus the matching torque wrench - all compact but easy to use. With this kit and these instructions, we seek to assist you in documenting the most spot-on measurement results possible in the most simple, quick and precise manner (e.g. without continuous re-calibration).

hr



1. Coaxial connections

Coaxial connections are made via simply interlocking high-precision plugs (m) and jacks (f). When bringing the parts together – and in particular when fitting an adapter or a calibration resistor – great care needs to be taken that the plug does not rotate into the jack but that the mechanical connection is made exclusively by the union nut. This is because even with a slight rotational movement the spring bellow of the jack will grind along the central point of the plug and can cause very fine dust to appear. This leads to contact problems and falsifies measurement results.



Abb. 1.1 Bolting the union nut of the coaxial cable to an adapter.

Before establishing the connection it is necessary to ensure that both parts, plug (m) as well as jack (f) are undamaged and completely clean. Even slight damage can affect the counterpart as well. Any defective components unconditionally must be replaced.

Special attention is also required regarding the position of the inner conductor – it needs to be absolutely straight. In case a part of the spring bellow of the jack is bent or has even broken off, the jack needs to be replaced in its entirety.

The easiest way to remove any contamination by dust or metal particles is to blow it off with compressed air (which needs to be free of grease or oil). Corresponding cans with compressed air are commercially available.



Abb. 1.2 Compressed air spray and lint-free wipes for cleaning purposes

In case of any dirt being stuck on the components a careful cleaning process using a lint-free paper wipe moistened with isopropanol is recommended. Please take care not to moisturize the synthetic materials too much, and dry them thoroughly prior to use – it is again best to use pressurized air.

Not suitable is regular methylated spirit since it does not evaporate without leaving any residue. In order to clean places which are difficult to reach, it is recommended to use a wipe wrapped around a toothpick. Loosen the contamination with light pressure and fully dispose of the wipe and the toothpick after each cleaning step.

In order to avoid contamination and damage in the first place, plugs as well as precision adapters and calibration standards should never be stored loosely without protective cap. Also, never place them upright onto their mating side. It is crucial that you use the plastic caps – as they are supplied or separately available – in order to protect the essential parts of plug and jack. Otherwise, the connectors may be easily damaged, depending on the type.



Abb. 1.3 Adapters with protective cap

Particular diligence is required when using the popular SMA-plugs. It often happens due to the special design of the plug, that it is not placed evenly and straight onto the jack but at an angle.

The robust pin of the plug will then damage the spring bellow of the jack. Make absolutely sure that the plug is attached straight in line and that the union nut is easily rotated. In current versions of the connector, e.g. the PC 3.50, this issue has already been considered in the redesign. If the union nut requires force to be rotated, start again and check that the plug has been inserted in a straight line. Another reason for a nut which is difficult to rotate may be a stiff coaxial cable which exerts a one-sided load onto the connection.

Using careful movement, check in which position of the cable the nut can be turned easily, then use this position to establish a secure and tight connection without damage to the delicate parts.



Abb. 1.4 SMA plugged-in at an angle



Abb. 1.5 PC 3.50 plugged-in at an angle

All plugs below the TNC-version (i.e. the screw-on variant of the BNC-type) should be tightened exclusively using a torque wrench. You may order wrenches with fixed torques for the most important plug types from elspec.

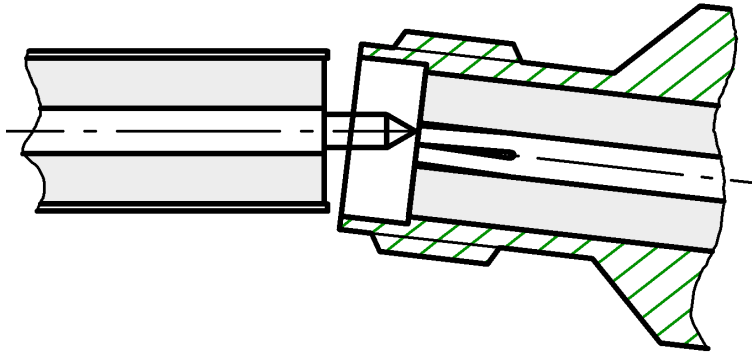
In case of doubt please consult the corresponding data sheets. The elspec expert team is at your disposal for further information.

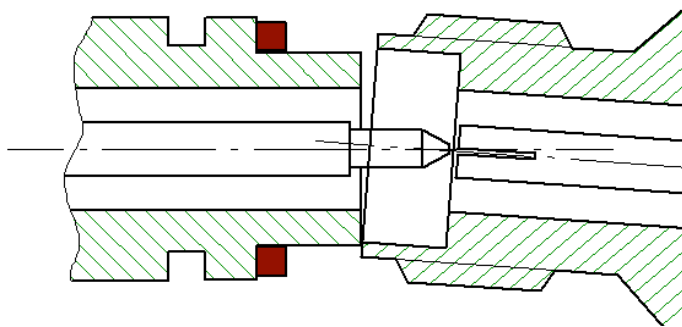

Abb. 1.6 Torque wrench

Expert advice

- For the cable type „semi-rigid“ always use connectors in which the union nut is held in place via a retainer ring.



2. The measurement setup

Coaxial cables interconnect various components of the measuring setup with each other. Ideally they would have a very small influence on the signal transmission. Good cables feature minimal attenuation, very small reflection coefficients and a stable phase. Please check ahead of usage whether the applied cables meet the requirements given in your setup. Data sheets include references to amplitude stability in the case of cable movement.

Modern vector analyzers are characterized by high production quality and a corresponding measurement accuracy. Some are already calibrated ex-factory. After reaching a constant operating temperature in the test locale, these are immediately operational. To measure a two-part device, the only thing missing is a set of connecting cables.



Abb. 2.1 Legend test cable/analyzer

The following example will exemplify how even the smallest equipment faults can have an effect: let us assume that the VNA achieves an accuracy of 50 dB for the measurement of the return loss. The line has a matching of 40 dB at one end and on the other end, further away, one of 31 dB. The phase rotates proportionally to the frequency according to the following equation:

$$\alpha = \frac{2 \cdot \pi \cdot l_{el} \cdot f}{c}$$

Expert advice:

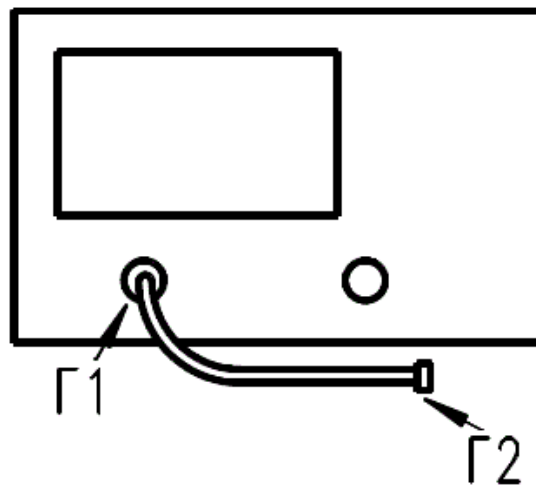
- Important: for all connectors a maximum fastening torque has been determined. You will find some types with corresponding values in the appendix.
- Caution: For some connector types, e.g. the SMA, there are low-cost versions on the market which only tolerate much smaller values.

The angle of the first reflection factor Γ_1 rotates with α_1 , as soon as the frequency shifts. The angle of the second reflection factor is α_2 . Due to the line length l_{ek} which in addition needs to be considered, this latter angle changes much more quickly compared to α_1 .

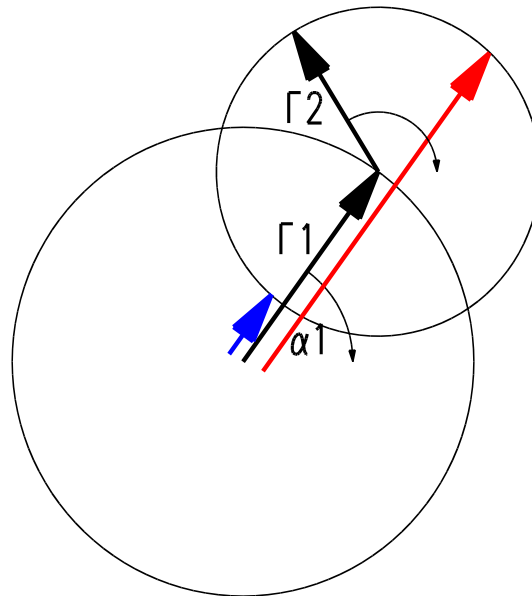

Describing the reflection factors as vectors and attaching Γ_2 , in the drawing, to the end of Γ_1 , we obtain the adjacent diagram.

However, since Γ_2 rotates faster, a superposition of the blue and the red arrows with shifting amplitude occurs. The two arrows represent the extreme values which occur and give, in the worst case, only a return loss of 28 dB. Additional adapters would deteriorate the situation even further.

This clearly shows that everything which is not part of the object under test needs to be considered in the calibration process.

Expert advice:

- After reaching a constant operational temperature in the VNA, the test setup is „ready to measure“.
- A stable working temperature in the test area/test room (air conditioning) is of great advantage.
- With it, evaluation of the signal stability and the phase input relative to the temperature drift is unnecessary.

All connecting cables merit careful consideration regarding quality although the requirements may not be as stringent here.

However, any cables directly used for measurements are subject to considerably higher demands, even in the context of the use of an VNA, and even if calibration processes are taking place.

The effect of cables of inferior quality cannot be „calculated out“ even with an exact calibration since the corresponding values will never remain constant. For example, simple cables do not have a stable phase when they are moved. Corresponding to the example above, the calculated correction values of the superimposed signals regarding the reflected signal do not fit anymore.

As soon as a test setup has reached a state where further changes are not necessary anymore, semi-rigid cables can be laid out in such a way that they do not have to be moved anymore – the phase changes will thus be minimal from then on.

The most sensitive section of the cable is the transition to the connector. For this reason, quality connectors have a kink protection; however even this cannot keep all stress away from the cable. It is therefore best to only moderately bend cables, and do so at a suitable distance from the connector.

Do avoid contusions caused by heavy objects, and do not buckle the cable - this could cause of excessive damage. Work carefully with the connectors and protect the delicate parts with protective caps when the connectors are not in use.



Expert advice:

- Please note that even very good cables and adapters can not have an unlimited accuracy and can degrade a measurement



3. Calibration

The most popular calibration method is „Open“, „Short“, „Load and Through“. Please ensure solid and stable connection of the test cables with the VNA – otherwise values may change later, rendering the calibration void.

For identical plugs of the same gender you will need a calibration kit with a specified adapter (through-connector).

Different connector types, on the other hand, require – for each type – the use of a calibration kit including a corresponding adapter (through-connector). Ideally, your setup will employ connectors of opposed or neutral gender. This way you can simply interconnect the two test cables for the „through“ calibration.

Using low test levels will increase the effect of system noise. If possible, you should switch on the averaging in the VNA so as to improve the accuracy.

After each measurement the result can be quickly checked by single-endedly connecting the „load“ and verifying that the RL is correct. In order to check the insertion loss, you may interconnect both test-ports. IL=0 dB ± system accuracy should be the result.

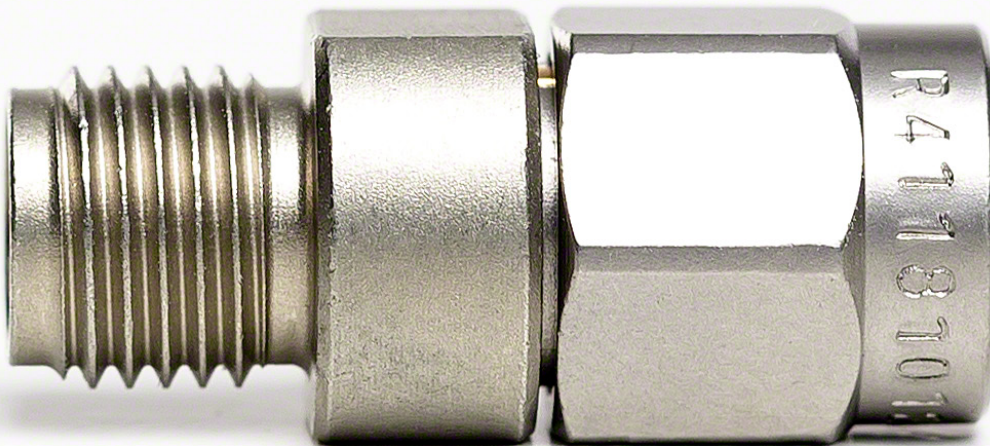

Expert advice:

- A carefully and precisely done calibration will remain stable for an extended period of time. Therefore storing the values is recommended; you may be able to use them again in the future.
- Less usage implies a longer service life: this rule holds for the calibration kit, as well.

4. Optimize matching

For a scalar measurement, a good matching of source and load is required in order to avoid superpositions of reflected waves which would possibly create errors. Power meters are usually well matched, but not every source. Connecting an attenuator can substantially dampen the waves as they come through.

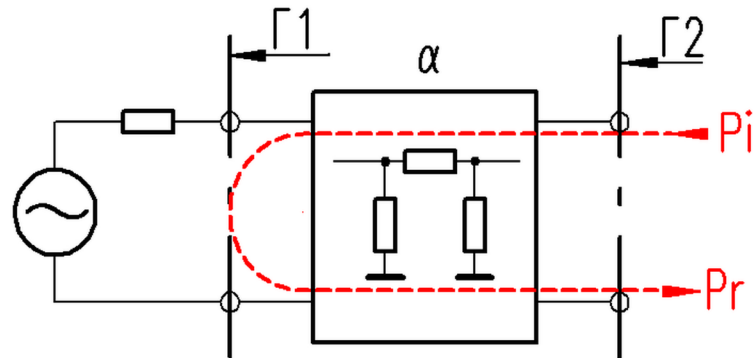

In our example we have $\Gamma_1 = -10\text{dB}$ and an attenuation of $\alpha = 6\text{dB}$.

$$\Gamma_2 = \sqrt{\frac{P_r}{P_i}}$$

$$P_r = P_i \cdot \alpha \cdot \Gamma_1 \cdot \alpha = 1\text{W} \cdot 0,2512 \cdot 0,1 \cdot 0,2512 = 0,00631\text{W}$$

$$\Gamma_2 = 0,07944 \Rightarrow 20 \cdot \log(0,07944) = -22\text{dB}$$

and a bit simpler using the logarithmic scale:

$$\Gamma_2 = 2 \cdot -\alpha + \Gamma_1 = 2 \cdot -6\text{dB} - 10\text{dB} = -22\text{dB}$$

The attenuator transformed the bad matching at -10dB into a good one at -22dB . However, this approach can not be continued endlessly since an attenuator will have a limited accuracy – which will manifest itself in the overall result.

5. VSWR (Voltage Standing Wave Ratio)

VSWR stands for „voltage standing wave ratio“ i.e. the proportion of the maximum and minimum voltage on a line. On a line there is not only a wave running in one direction but also a return wave in the other direction. Both corresponding voltages are superimposed and result in an addition and subtraction of both components. This is expressed via the VSWR.

Maximum voltage: U_{max} $VSWR = \frac{U_{max}}{U_{min}}$

Minimum voltage: U_{min} $VSWR = \frac{1+r}{1-r}$

for $R > Z_0$ $VSWR = \frac{R}{Z_0}$

for $R < Z_0$ $VSWR = \frac{Z_0}{R}$

6. The reflection factor

The reflection factor indicates how much energy is reflected at a connected port (termination).

Termination resistance: R $r = \frac{R - Z_0}{R + Z_0}$

Reference resistance: Z_0 $r = \frac{VSWR - 1}{VSWR + 1}$

$$\Gamma = 20 \cdot \log(r)$$

7. The unit „Bel“

In communication systems it is most often easier to do calculations using logarithmic units rather than linear units. The corresponding unit „Bel“ was named after Alexander Graham Bell. Since doubling the power equals 0,3 Bel, it is more practical to work with a tenth of the unit, the deci-Bel (dB).

Power 1: P_1

Power 2: P_2

$$L = 10 \cdot \log \frac{P_1}{P_2}$$

If voltages are used, the dB-value is calculated to:

$$P = \frac{U^2}{R} \qquad L = 10 \cdot \log \left(\frac{U_1^2}{U_2^2} \cdot \frac{R}{R} \right) = 10 \cdot \log \left(\frac{U_1}{U_2} \right)^2 = 20 \cdot \log \left(\frac{U_1}{U_2} \right)$$

Experten Tipp:

- Avoid torsion movements around the kink-protection area; this can cause stress and strain in the film-construction of the cable interior, and thus lead to micro-breaks. The ground connection may become fragile, and erroneous test signals may result. Your test setup would be in a critical state!
- Review your cables every three months. Start with a visual inspection of the plugs and jacks and then measure the cable. Compare the current reading with the last one. Depending on the results you may be able to re-calibrate or to adapt your calculations. In case of doubt always replace the cable.

8. The coaxial cable

D : diameter outer conductor

d : diameter inner conductor

ϵ_r : relative permittivity

Z_0 : wave impedance Ω

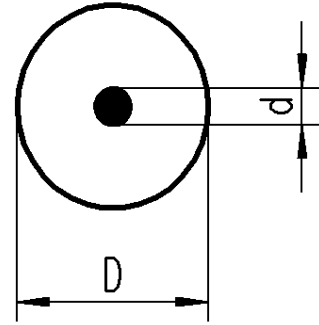

$$Z_0 = \frac{60 \Omega}{\sqrt{\epsilon_r}} \cdot \ln\left(\frac{D}{d}\right)$$

$$D = d \cdot e^{\frac{Z}{60 \Omega} \cdot \sqrt{\epsilon_r}}$$

$$d = \frac{D}{e^{\frac{Z}{60 \Omega} \cdot \sqrt{\epsilon_r}}}$$

If the inner conductor is not positioned centrally, the wave impedance changes.

$$a = x + \frac{D}{2}$$

$$Z = \frac{60 \Omega}{\sqrt{\epsilon_r}} \cdot \ln\left(\frac{D}{d}\right) \cdot \left(1 - \frac{4 \cdot y^2}{(4 \cdot a^2 - d^2) \cdot \log\left(\frac{2 \cdot a}{d}\right)}\right)$$

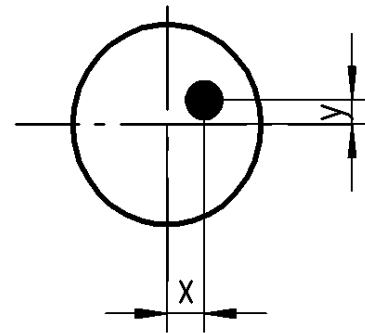

It is important to know up to which frequency a coaxial cable may be used before the next higher mode, TE₁₁, can start to propagate. For this the first zero of the following equation needs to be solved for x :

Bessel-function of the first type: J_0, J_1

Bessel-function of the second type: Y_0, Y_1

$$R = \frac{D}{2}$$

$$A = \frac{R}{r}$$

$$r = \frac{d}{2}$$

$$\frac{v}{c_0} = \sqrt{1 - \left(\frac{\lambda_0}{\lambda_c}\right)^2}$$

$$\left(J_0(x \cdot A) - J_2(x \cdot A)\right) \cdot \left(Y_0(x) - Y_2(x)\right) - \left(Y_0(x \cdot A) - Y_2(x \cdot A)\right) \cdot \left(J_0(x) - J_2(x)\right) = 0$$

The cutoff frequency is:

$$f_c = \frac{x \cdot c_0 \cdot (A + 1)}{(R + r) \cdot 2 \cdot \pi \cdot \sqrt{\epsilon_r}}$$

The coefficient x shows the following dependency on the diameter relations:

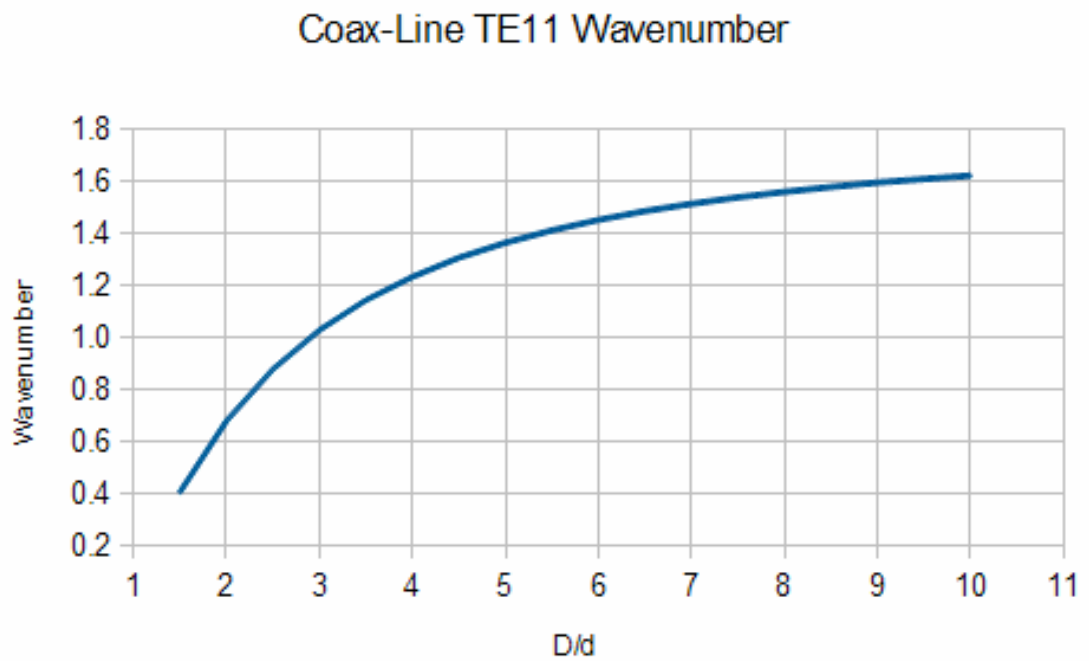

If solving the equation is not desirable, a first calculation is possible using values taken from the curve shown above.

9. Various types of connectors

7/16

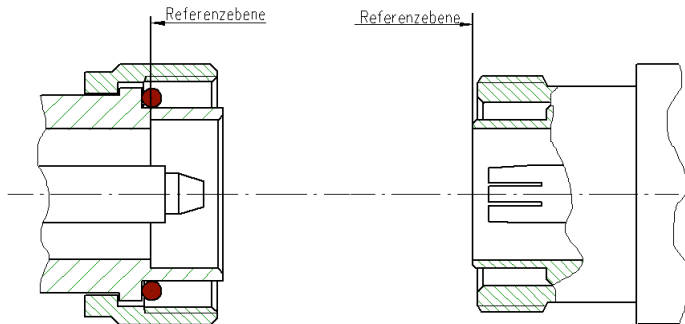

Frequency range	DC – 8,3 GHz
Power load	1800W @ 1 GHz 800W @ 4 GHz
Plug cycles (dependent on the material)	≥ 500
Fastening torque (dependent on the manufacturer)	25 – 30 Nm

N

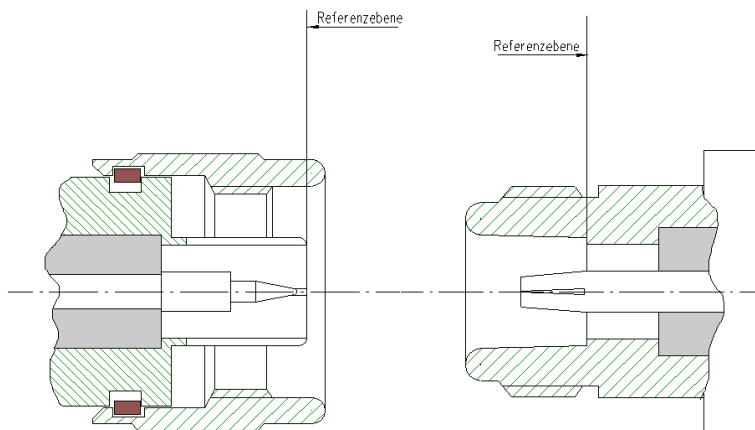

Frequency range	DC – 11 GHz
Power load	1000W @ 1 GHz 700W @ 2 GHz
Plug cycles (dependent on the material)	≥ 500
Fastening torque (dependent on the manufacturer)	1,7 Nm

SMA

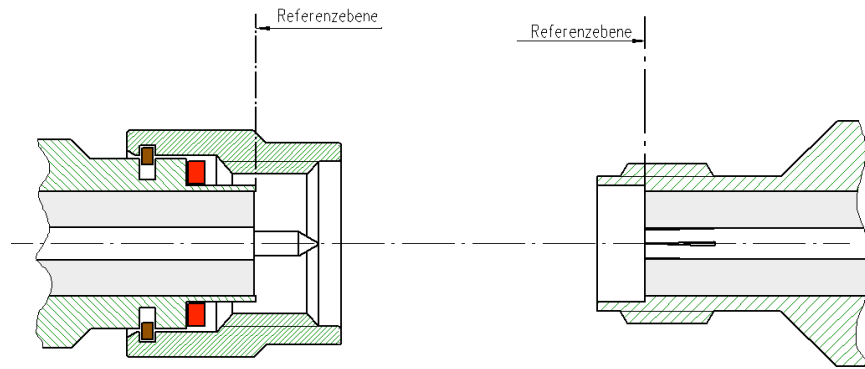

Frequency range	DC – 18 GHz
Power load	200W @ 2,2 GHz
Plug cycles (dependent on the material)	≥ 100 - 500
Fastening torque (dependent on the manufacturer)	0,8 - 1,1 Nm

PC 7

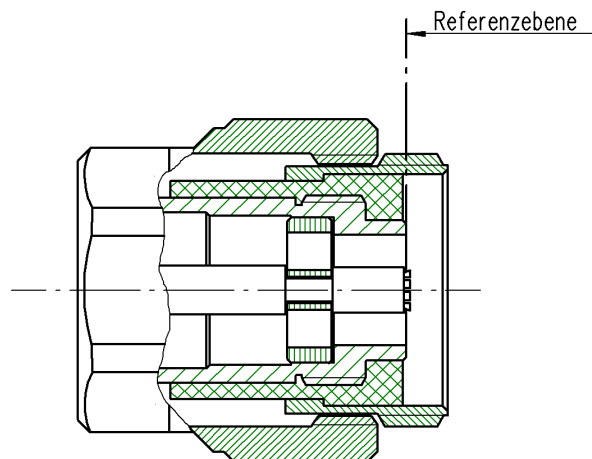

Frequency range	DC – 18 GHz
Plug cycles (dependent on the material)	≥ 5000
Fastening torque (dependent on the manufacturer)	1,36 Nm

PC 3.50

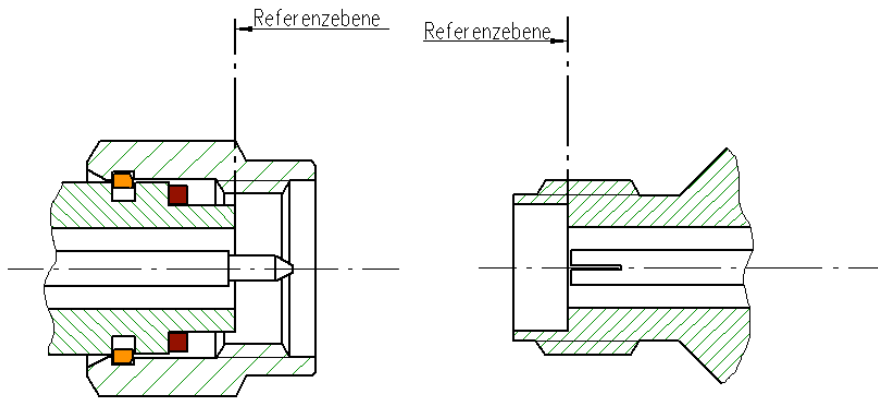

Frequency range	DC – 26,5 GHz
Plug cycles (dependent on the material)	≥ 500
Fastening torque (dependent on the manufacturer)	0,80 Nm ... 1,10 Nm

Legal

©copyright 2016 by el-spec GmbH

Concept, text, drawings: Stefan Burger, Delta Gamma RF Expert, Melbourne, Australia

Layout and design: Udo Klünsch | kpr kommunikation, Geretsried

Photos: Udo Klünsch | kpr kommunikation

All – except page: 7 (1.2) – unknown

This document is protected by copyright. Any use without the consent of el-spec GmbH is prohibited and punishable. In particular, this applies for reproductions, translations, and storage in electronic systems.

el-spec GmbH

Lauterbachstr. 23c

82538 Geretsried-Gelting

T.: +49 81 71 43 57-21/-22

F.: +49 81 71 43 57-99

info@elspegroup.de

Managing director: Thomas Weber

www.elspecgroup.de

10. The portable elspec Premium Measurement Kit 18GHz



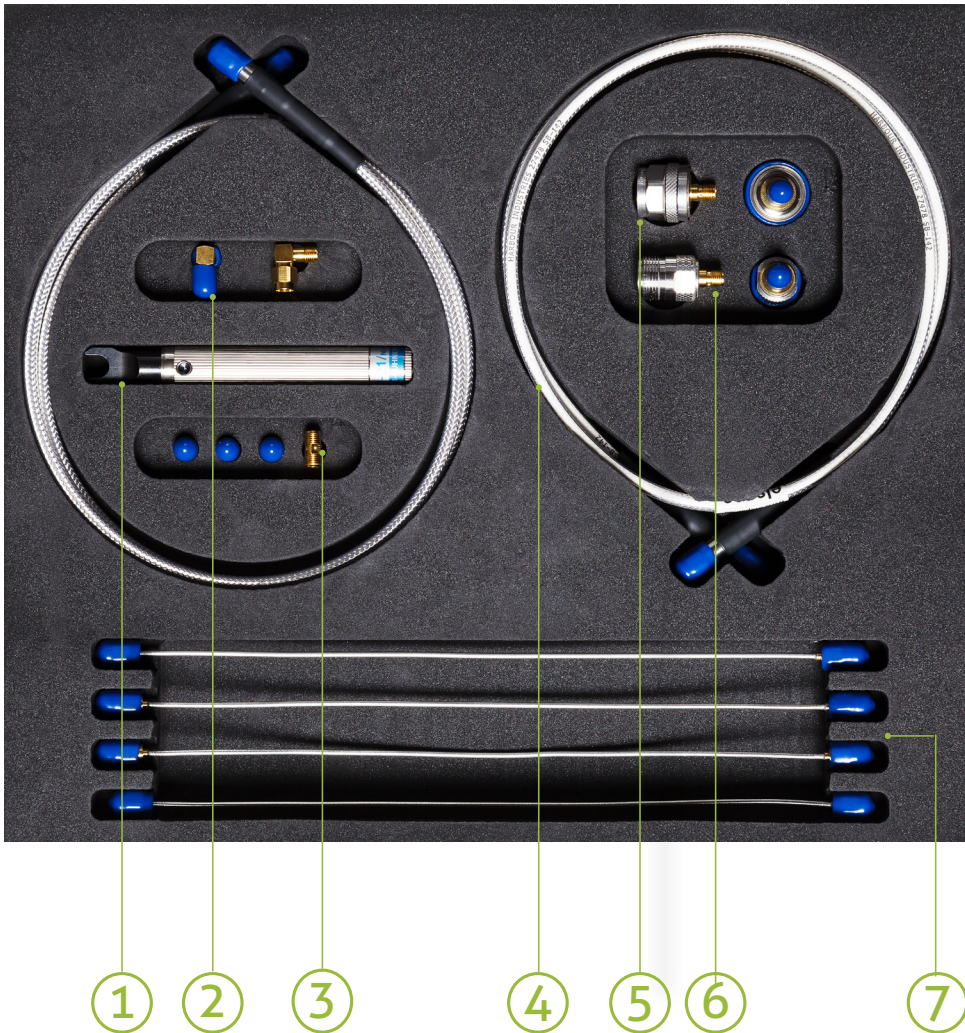

Contents:

- 1. Torque wrench SMA
- 2. SMA Anglel (m/f), 2 pcs.
- 3. SMA (f) / SMA (f), 4 pcs.
- 4. Microwave Cable Assembly 18GHz,SB142 - SMA (m) / SMA (m) - 1000, 2 pcs.
- 5. N (m) / SMA (f), 2 pcs.
- 6. N (f) / SMA (f), 2 pcs.
- 7. Jumper-Cable Sucoform® 86, Semi-Rigid flexibel, SRF SMA (m) / SMA (m) - 0250, 4 pcs.

In addition stored in the lid (w/o picture)

- 8. VSWR-table 1 pcs.
- 9. writing pad, 1 pcs.
- 10. ball-point pen, 1 pcs.
- 11. business card of your elspec contact
- 12. Two keys for the case

Notes



Notes

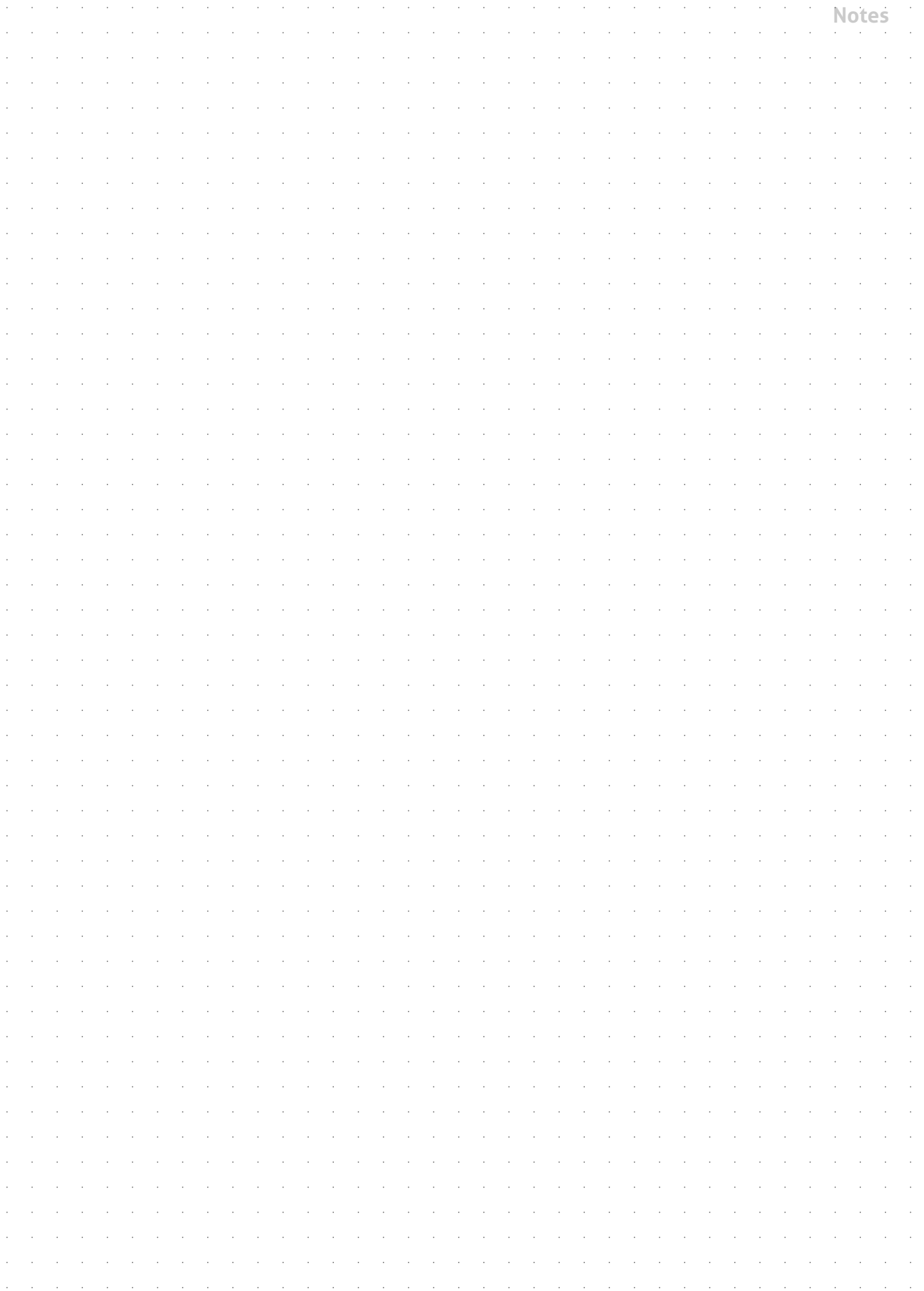

Notes



Notes



Notes





el-spec GmbH
Lauterbachstr. 23c
D-82538 Geretsried-Gelting, Germany
Tel. +49 (0) 8171-4357-23
Fax +49 (0) 8171-4357-99
sales@elspecgroup.de
www.elspecgroup.de